

RUGER MODEL: RC1000

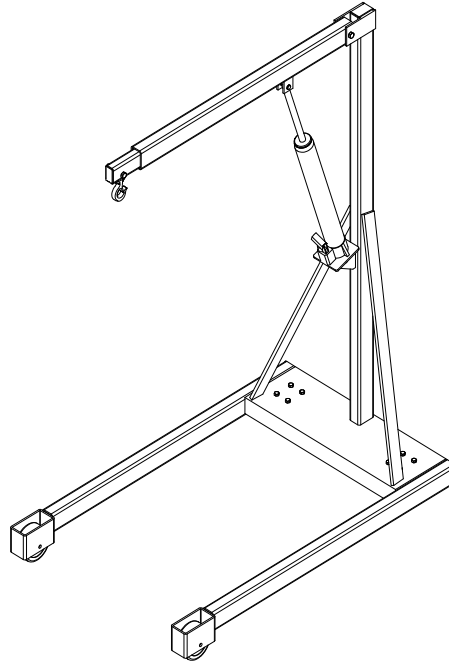

Engineered Handling Solutions Since 1869



RC1000

Standard Features:

- 1,000 lbs maximum rated capacity
- Straddle leg design eliminates the need for counterweights
- Meets Ruger's structural engineering standards for 150% rated lifting capacity
- Meets ASME PALD standards for shop cranes, conforms to ANSI Z535 standards
- Self contained manual hydraulic pump
- Built-in hydraulic pressure relief valve
- Needle release valve permits pin-point load control
- Manual adjustable telescopic boom
- Phenolic resin wheels with rear caster brake
- Swivel hook with safety latch
- Steel construction and standard Ruger blue paint

Optional Accessories:

- Bolt on floor lock kit
- Steel wheels
- Polyurethane wheels
- Swivel mast & boom – Limited swing angle
- Custom engineered manual winch rated for lifting
- Custom engineered stainless steel construction

The David Round Company, Inc. - Ruger Division - 10200 Wellman Rd - Streetsboro, OH 44241
Phone: 330-656-1600 - Fax: 330-656-1601 - info@davidround.com - www.rugerindustries.com

Prices, specifications, and options are subject to change without notice. All Ruger products are shipped F.O.B. Streetsboro, OH 44241

RUGER MODEL: RC1000



Designers & Manufacturers of Hydraulic Load Lifting and Material Handling Equipment

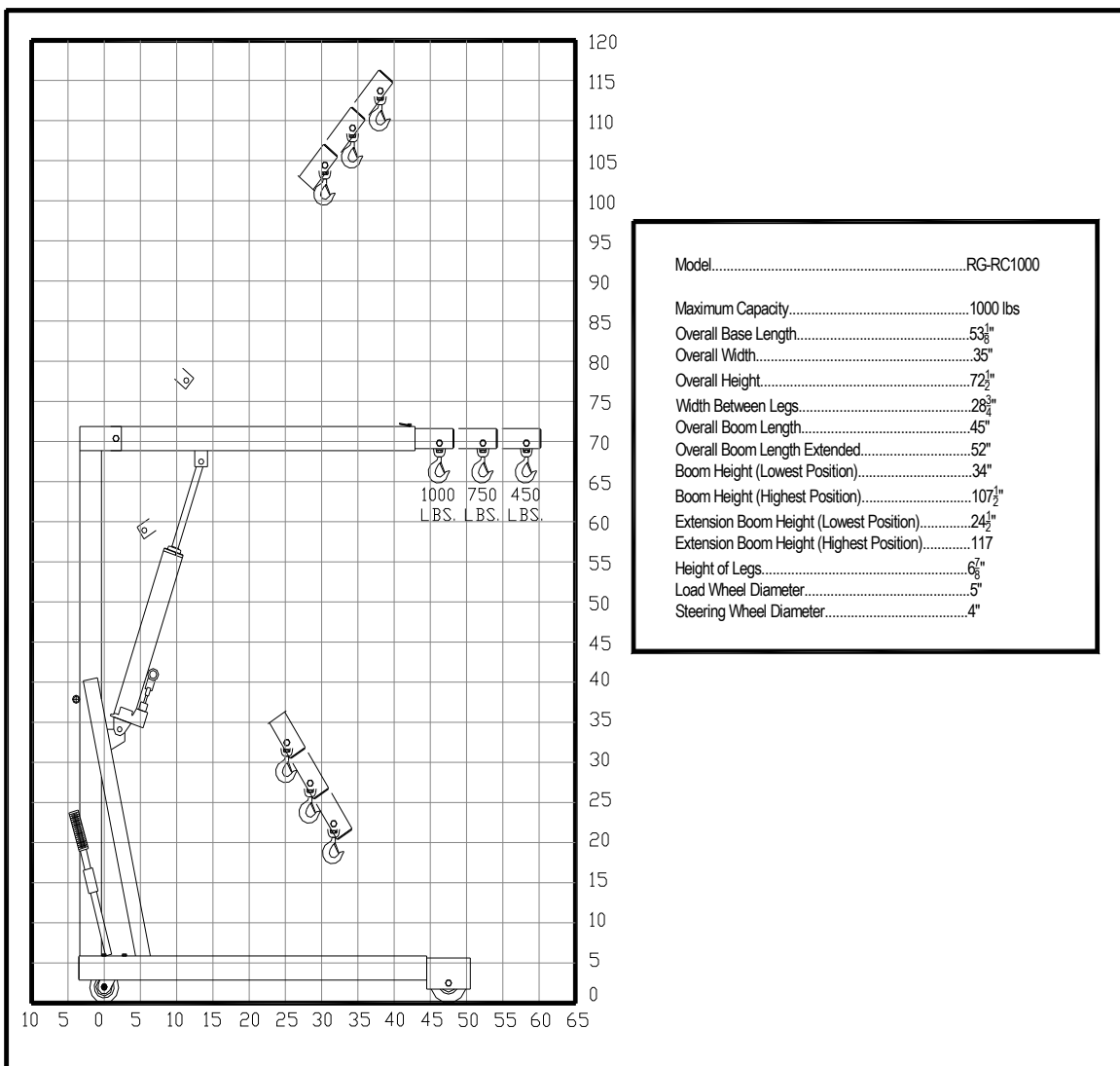

The David Round Company, Inc. - Ruger Division - 10200 Wellman Rd - Streetsboro, OH 44241
 Phone: 330-656-1600 - Fax: 330-656-1601 - info@davidround.com - www.rugerindustries.com

Prices, specifications, and options are subject to change without notice. All Ruger products are shipped F.O.B. Streetsboro, OH 44241

Copyright 2011