

203 SERIES

High-performance engineered winches meet demanding application requirements.

Unlimited Capability

Each 203 series winch is specifically designed for its intended application.

- Single line capacities from 1/2 to over 100 tons.
- Cable drums sized to meet the rope storage requirements, fleet angle restrictions and space limitations of each application.
- Modular sealed gear sets, sized for intended service factor, develop almost any required line speed from less than 1 FPM to over 150 FPM.
- Motor, band, fan, disc and Weston-style brakes as well as vector drives are just some of the available load holding options.
- Free-spooling drum clutches, powered levelwinds, special drum grooving patterns and fairleads are easily integrated with 203 series winches to maximize rope handling and spooling efficiency.

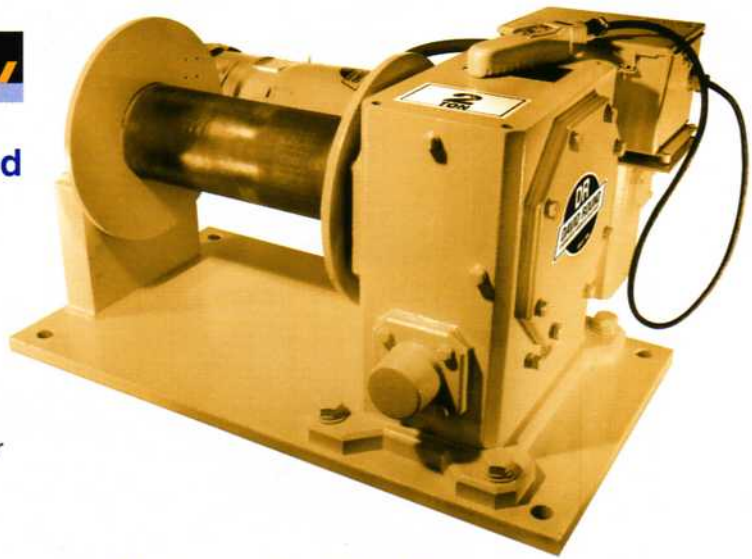

Marine-grade winch with weather-resistant components

Built to Specifications

203 Series winches are either built to OEM, government, military and industrial specifications or David Round's own standards.

- Upon request, winch designs may be certified by a registered professional engineer.
- In-the-field reverse engineering is available to design drop-in replacement winches.
- All winches are load tested and certified prior to shipment.

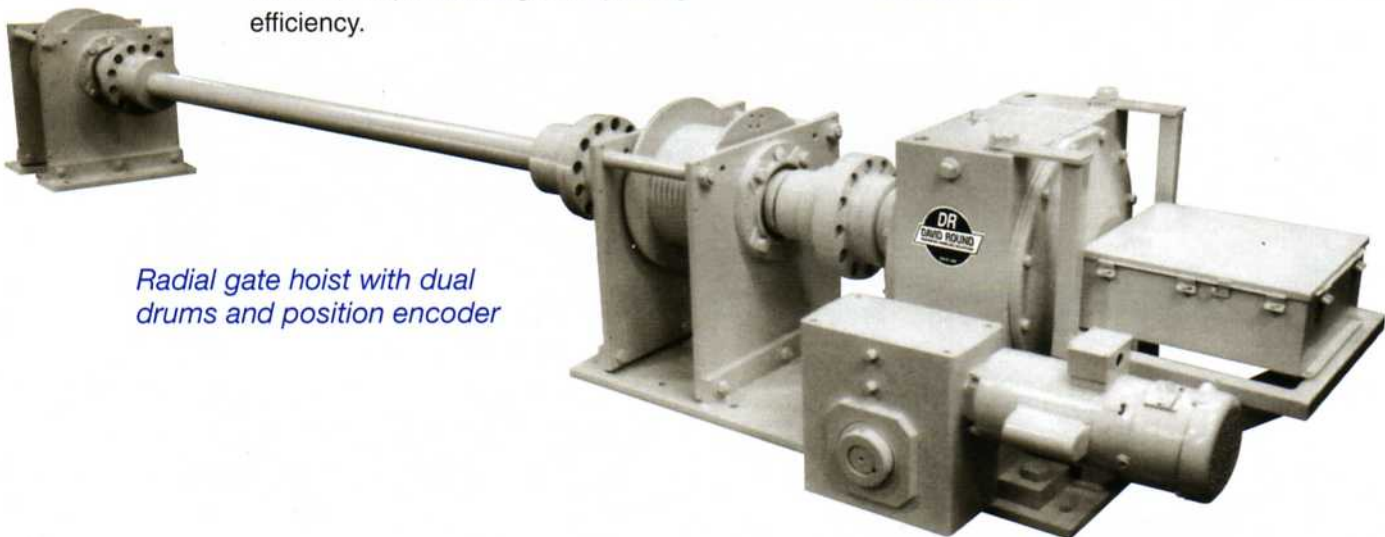

Radial gate hoist with dual drums and position encoder

THIS EQUIPMENT IS NOT TO BE USED FOR LIFTING OR SUPPORTING PEOPLE.

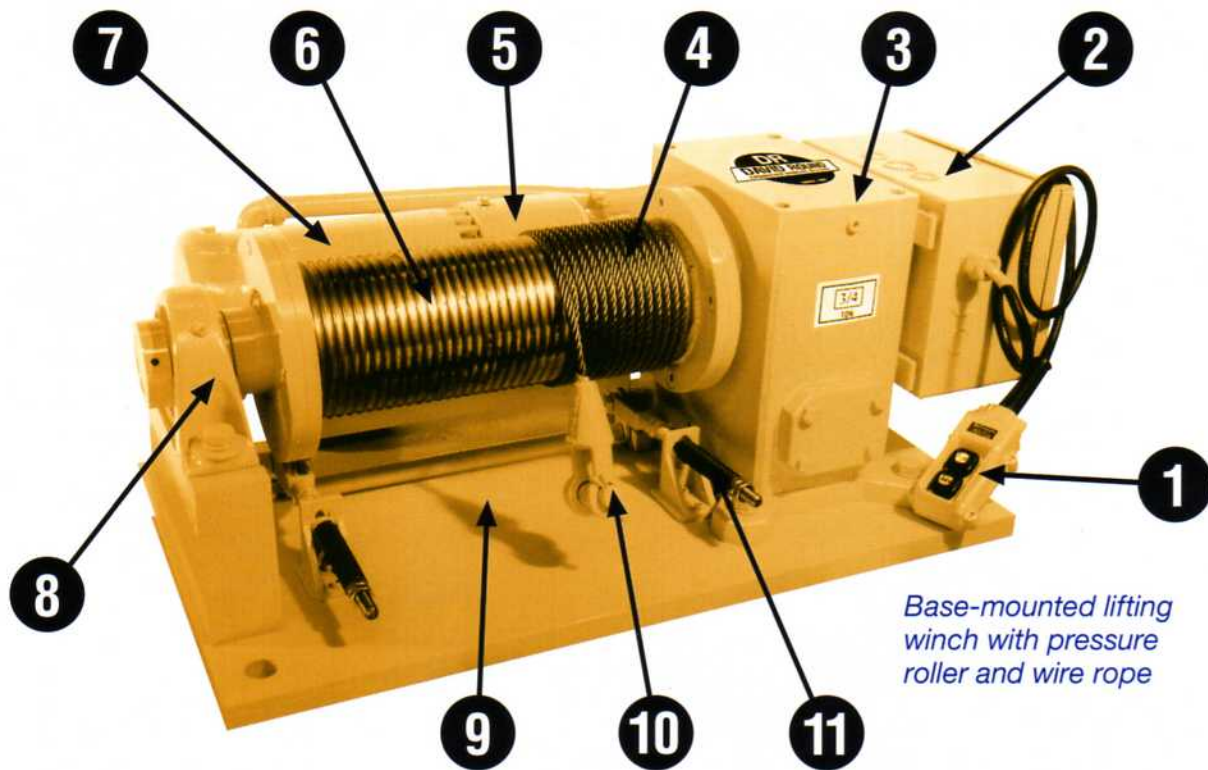

Base-mounted lifting winch with pressure roller and wire rope

- 1 Pendant-** Various button configurations available for pendants and remote controls.
 - 2 Controls-** Single and two-speed control packages available with a standard reversing starter or choose variable speed winch operation with an AC inverter or vector drive. Weather-resistant, marine grade and explosion-proof enclosures available.
 - 3 Gearing-** 100% Sealed gearing with oil bath lubrication unless otherwise specified. Right angle, in-line and planetary gear sets accommodate all reduction and space limitation requirements.
 - 4 Wire Rope-** Available upon request, wire rope is sized for winch capacity and application.
 - 5 Motor Brake-** Provided unless otherwise specified to hold suspended or unstable loads.
 - 6 Cable Drum-** Sized to meet loading, cable, fleet angle and space restriction requirements.
 - 7 Motor-** Electric motor properly sized for starting and running loads and configured for environmental conditions.
 - 8 Bearings-** Precision self-aligning pillow block or flange cartridge bearings with grease fittings.
 - 9 Mounting-** Space-saving frame layouts may be sized to match existing mounting requirements.
 - 10 Fittings-** Swivel hooks, blocks, clevis fittings and other rope attachments are available.
 - 11 Spooling Aids-** Pressure rollers, fairleads, level winds and sheaves available for cable control.
- Finish-** Winches painted safety yellow unless otherwise specified. Epoxy paint is available.
- Safety Devices-** Hook travel limit switches, drum guards, overload detection / auto-shutdown systems, audible / visible alarms and other safeguards are available.

THIS EQUIPMENT IS NOT TO BE USED FOR LIFTING OR SUPPORTING PEOPLE.

203

SERIES

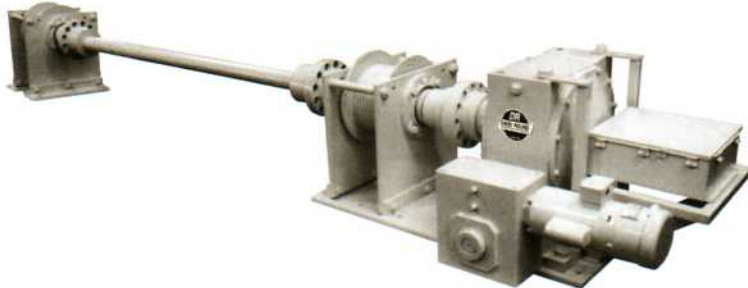

Radial Gate Hoist

Double-drum base-mounted winch lifts radial gate with two cables, instead of one, to balance and stabilize the wide gate more effectively. Winch positions gates found in irrigation and flood canals in order to control water flow.

- Grooved double drums
- Shaft encoder for drum position feedback
- Winch design certified by professional engineer



Continuous Tension Winch

Incorporating an oil shear clutch, this hydraulic winch provides continuous line pulling tension for construction and web handling equipment to automatically advance pipe bursting heads and roller carriages when back tension diminishes.

- Liquid-cooled wet disc hydraulic clutch
- Sealed planetary gearing
- Hydraulic motor with directional controls



Base-Mounted Lifting Winch

Frequently used in processing applications for conveyor positioning and for hatch, grate and pump lifting, this base-mounted lifting winch is available as a stand-alone unit or as part of an integrated system with sheaves and jib cranes.

- Motor brake holds load in position
- Rotary limit switch restricts hook travel
- Grooved drum for consistent cable take-up

THIS EQUIPMENT IS NOT TO BE USED FOR LIFTING OR SUPPORTING PEOPLE.

● Marine-Grade Winch

Weather resistant components make this winch ideal for shipboard use including anchor, ladder and gangway lifting as well as buoy handling.

- Sealed and accessible gearing
- Optional free-spooling capability
- Hydraulic units available



● Cart-Pulling Winch

Used under power to pull trailers and mobile homes through production, this winch is also available in push-pull and traction style designs.

- Free-spooling drum for quick manual payout
- Variable speed air lever controls
- Sealed gearing provides years of reliable service



● Line Tensioning Winch

Unlike other winches with load holding brakes, this winch releases cable at a preset line tension, making it ideal for cable stringing applications.

- Adjustable band brake
- Manual operation
- Often integrated with other cabling equipment

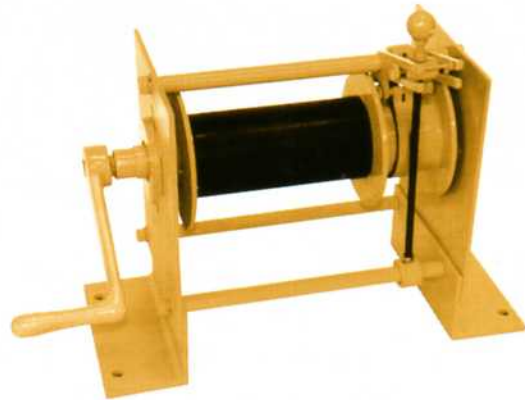

● Furnace Door Lifting Winch

Available in single or dual line configurations, this furnace door lifting winch features high starting torque to pull doors free from seals.

- High-torque electric motor
- Sealed gearing with oil bath lubrication
- One, two and variable speed models

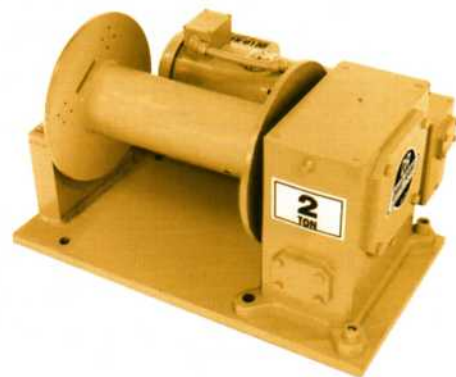

THIS EQUIPMENT IS NOT TO BE USED FOR LIFTING OR SUPPORTING PEOPLE.